

# Development of Virtual Sensor Networks to Support Accident Monitoring Systems

Rizwan Ahmed<sup>1</sup>, Pak Sukyoung<sup>1</sup>, and Gyungyoung Heo<sup>1</sup>, Jung-Taek Kim<sup>2</sup>, Seop Hur<sup>2</sup>, Soo Yong Park<sup>2</sup>, Kwang-II Ahn<sup>2</sup>

<sup>1</sup>*Department of Nuclear Engineering, Yongin-si, Gyeonggi-do, 446-701, South Korea*

*rahmed.ne@gmail.com  
pak.sukyoung@gmail.com  
gheo@khu.ac.kr*

<sup>2</sup>*Korea Atomic Energy Research Institute, Yuseong-gu, Daejeon, 305-353, South Korea*

*jtkim@kaeri.re.kr  
shur@kaeri.re.kr  
sypark@kaeri.re.kr  
kiahn@kaeri.re.kr*

## ABSTRACT

In a nuclear power plant (NPP), most of the systems are linked due to processes of fluid flow, heat transfer etc., and their natural tendency to respond to changes during accident conditions. These relationships can be utilized to develop smart applications for plant accident monitoring and management. In this research, the statistical relationships among the process parameters have been analyzed. It has been embarked that the characteristics of a safety system during a particular interval can be estimated by utilizing the other affected parameters, employing statistical correlation and regression models developed from the simulation data offline, when evaluated for the same set of conditions on accident sequence and safety systems. The proposed methodology has been demonstrated for a specific loss of coolant accident scenario using correlation coefficient and neural networks, for the time interval when containment spray system was initiated at the particular stage of accident progression and remained operational for some designed time. Virtual sensor networks were constructed for the estimation of reactor vessel level during that time period, which demonstrates the realization of methodology. The estimations from such virtual sensor networks are expected to improve by utilizing the importance measures and concepts to generalize the neural networks. Also, correlation voting index (CVI) provides a capability to select a set of related outputs, which would be used as a yardstick for comparing results in case, missing or uncertain inputs are present.

## 1. INTRODUCTION

Nuclear instrumentation and control (I&C) system is to provide reliable information on process parameters during normal and abnormal conditions. It should also have the capability to represent information regarding process and safety parameters in easily interpretable manner by numbers/displays. The display capabilities of I&C systems have been greatly improved after the TMI event 1979 where operators were failed to take right actions due to misinterpretation of available signals. Modern I&C systems are programmed with computers where they can simultaneously utilize the monitoring data for sensor or equipment fault diagnosis. Such intelligent systems have made online calibration and testing of sensors a reality. However, during the Fukushima accident in Japan, we could observe the modern I&C was again failed due to a combination of reasons that appeared to include: loss of power, evaporation of liquid in sensing lines, failure of sensors due to environmental conditions, instrument ranges that were not suitable for monitoring plant conditions, and lack of alternative data for use in validating instrument readings. Therefore, the capability of I&C systems is extremely important during severe accidents characterized by a combination of basic events and followed by failures of designed safety systems.

Nuclear industry has launched exhaustive research projects to address safety challenges in the severe accidents. At a broader level, for a complete accident management and emergency planning the areas to be focused are transitional procedures, onsite and offsite interactions, design and equipment and, and human and organizational factors. It has

---

Ahmed, Rizwan et al. This is an open-access article distributed under the terms of the Creative Commons Attribution 3.0 United States License, which permits unrestricted use, distribution, and reproduction in any medium, provided the original author and source are credited.

been suggested that the severe accident management guidelines (SAMG) could only be useful if the monitoring of critical parameters is somehow made available to the operator, even in station blackout condition as mentioned by (American Nuclear Society, 2012) and (US Nuclear Regulatory Commission, 1983). Loss of information on process parameters increases the chances of information misinterpretation at control room which may lead to wrong operator actions.

This research was motivated as a method to resolve aforementioned challenges. Our strategy is based on the development of an indirect way that is, a method to assess the safety critical parameters from other statistically related parameters.

## 2. MATERIALS AND METHODS

US NRC's Regulatory Guide 1.97 provides the basic requirements for human-machine interface systems including I&C systems and for the monitoring of radioactivity releases following an accident. The SAMG classifies the important parameters in classes A-E (referred as SAMG parameters herein). Type A parameters are to provide primary information for manual operation. Type B parameters to provide information regarding the accomplishment of safety functions such as reactivity control, core cooling, maintain reactor coolant integrity, maintaining reactor containment integrity. Type C parameters are to provide information regarding variables that have a potential for causing a containment breach such as core exit temperature (CET), reactor coolant system (RCS) pressure, hydrogen concentration, containment pressure, and so on. Type D parameters are to indicate the operation of safety systems such as residual heat removal system, safety injection systems, refueling water storage tank level, primary coolant system, condensate storage tank level, containment cooling systems, radwaste systems, ventilation systems, power supplies etc., and Type E parameters are to indicate the amount of radioactive material to be released in case of containment breach. IEEE has also developed standards to support the specification, design, and implementation of accident monitoring instrumentation of NPPs. The recent document IEEE Std-497 (revision 2010) provides criteria for selection, performance, design, qualification, display and quality assurance of the nuclear I&C system (IEEE Power and Energy Society, 2010). Westinghouse has proposed an advanced system for post-accident monitoring (PAM) to implement the SAMG parameters (Westinghouse Electric Company, 2012). The representative parameters are CET, reactor vessel level, hot and cold leg temperatures, RCS pressure, and so on (referred as PAM parameters herein).

The focus of this research was on the PAM and SAMG parameters which should be secured during a severe accident to see the working of safety functions and their

influence on accident progression. In this study the methodology to improve the information availability, by utilizing the statistical correlations among the PAM and SAMG parameters has been presented with a case study. Accident simulation data generated from the MAAP code for a probable loss of coolant accident (LOCA) scenario that led to containment damage (Park, 2009). The MAAP code generates time series data for more than 800 parameters following an initiating event for 2 days. This study was initiated to explore the following technical areas (Ahmed, 2013),

1. The statistical correlation of a process parameter with other parameters provides a basis for securing PAM parameters from SAMG parameters. The correlations among the process parameters can be utilized to estimate one parameter from the others. This would increase the virtual redundancy of the critical information.
2. The relationships among the process variables can be used to develop several virtual networks to generate an important parameter. Therefore, we can have capability of virtually supplying a safety-related sensor's information during normal operation of critical sensor and also this information will be available if the original signal is unavailable to the operator.

## 3. DEVELOPMENT OF PAM-SAMG RELATIONSHIP

Thousands of sensors are installed at an NPP to measure parameters that are important to draw metrics for its performance and safety condition. However, a smaller set of parameters is vital for safety management. US NRC has provided a SAMG on preferred process parameters be monitored during and following an accident. We hypothesized that the statistical relationships among the process parameters can be utilized to serve as virtual sensor networks where PAM parameters could be estimated by several sets of SAMG parameters. However, the sets of SAMG parameters used to estimate a PAM parameter are expected to differ due to the underlying boundary conditions and involved safety systems.

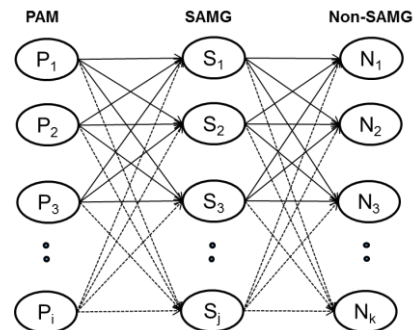

Figure 1: Structure of virtual sensor network.

The methodology can be directly extended to develop virtual networks to estimate SAMG parameters from other non-SAMG parameters as well. A system of such virtual networks is shown in figure 1. The connecting lines mean the statistical correlation and not a physical connection by wire or other data transferring mean. The complete stages for developing virtual networks for estimating PAM parameters are shown in figure 2. The remaining subsections are to discuss major processing step in brief.

### 3.1. Simulation Database

Major initiating events (1) large loss of coolant accident (LBLOCA), (2) medium loss of coolant accident (MBLOCA), (3) small loss of coolant accident (SBLOCA), (4) station blackout accident (SBO), (5) loss of off-site power accident (LOOP), (6) steam generator tube rupture accident (SGTR), and (7) loss of feed-water accident (LOFW) were simulated by using the MAAP code for Korean standard NPP, OPR-1000 (Park, 2009). The database comprised of a total of 70 accident scenarios analyzed on the basis of probabilistic safety analysis of OPR-1000 and presents the data for more than 800 thermal hydraulic and source term parameters for 72 hours following an accident.

### 3.2. Scenario Analysis

Accident management strategies have been developed and safety systems are designed to initiate when certain set of conditions meet and work for a particular time interval. With the MAAP code, the generated accident scenarios were to represent severe accident conditions, where several safety systems were assumed to fail. A set of representative LOCA scenarios are shown in figure 3 via event tree diagram, where the working of safety systems such as high pressure safety injection system (HPSIS), low pressure safety injection system (LPSIS), containment spray system (CSS) and cavity flooding system are conceivable. Scenarios having end state marked by a prominent yellow colored circle represent that the final Plant Damage State (PDS) was containment damage. To develop a particular application for severe accident monitoring system, the time intervals associated with the working or failure of safety systems should be considered to identify relationship among the parameters.

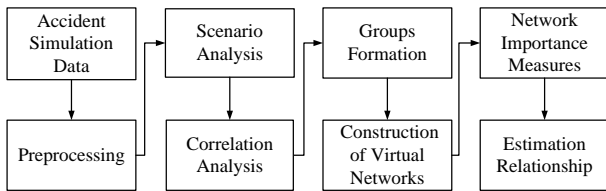

Figure 2: Steps for the development of parameter estimation relationships.

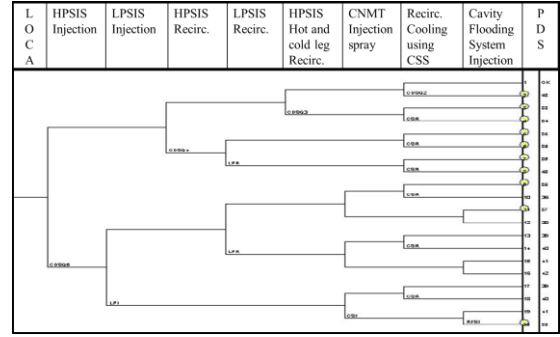

Figure 3: Event tree for a LOCA scenario.

### 3.3. Groups Formation

For the development of virtual sensor networks, statistical relationship among the process parameters was required during working or failure of a safety system. Correlation coefficient is the most widely used statistical measure and is being used in process industry as a basis for grouping related variables for online monitoring applications (Ahmed, et al., 2012; Heo, et al., 2012). Equation (1) defines the simple correlation for two variables ‘x’ and ‘y’ having ‘n’ values in each.

$$r = \frac{\sum_{i=1}^n (x_i - \bar{x})(y_i - \bar{y})}{(n-1)s_x s_y} \quad (1)$$

Where  $s_x$  and  $s_y$  are sample standard deviations for given  $x$  and  $y$  vectors, respectively. An algorithm was implemented to collect top correlated SAMG parameters with PAM parameters on the basis of absolute value of correlation coefficient.

### 3.4. Construction of Virtual Networks

A virtual sensor network is a group of statistically related physical sensors where some of the signals are taken as input to produce others employing a regression model. Possible input combinations for the estimation of a parameter  $P_n$  from three inputs  $S_1$ ,  $S_2$  and  $S_3$  are shown in figures 4 (a), 4 (b) and 4 (c). Where the subscripts  $i$ ,  $j$  and  $k$  of input signal ‘S’, can assume any values from the set (1, 2, 3) for generating the same output  $P_n$ . Therefore, seven (7) virtual networks can be developed for a system having three inputs and one output. For each virtual sensor network to be operational a regression model is indispensable. Among several regression models, ANN is widely used to map between a set of inputs and a set of targets and is quite robust. An ANN is an information processing system characterized by its architecture, training algorithm and activation function. A two-layer feed-forward network with sigmoid hidden neurons and linear output neurons is mostly used (Fausett, 1994). For ANN training Levenberg-Marquardt back propagation algorithm is generally preferred, in case there is not enough memory, the scaled

conjugate gradient back propagation is recommended (Beale, et al., 2012).

### 3.5. Network Importance Measures

The estimations from a virtual sensor network are subjected to changes depending upon characteristics of underlying regression model and sensors' uncertainties. The characteristics of regression models are beyond the scope of this paper however, a concept of importance measures is introduced here to characterize the influence of sensors' uncertainties on the accuracy of estimations computed from a regression model. It is therefore, quite conceivable that the importance measures will adhere to the characteristics of underlying regression model (Ahmed, 2013). In this study the outputs of virtual sensor networks are produced by using ANN therefore, a mean square error (mse) was used to define the importance measures, since it is the basic measure of neural network performance and is widely used due to its ease of computation and quick optimization (Masters, 1993). The mathematical relationship to calculate 'mse' is given in equation (2).

$$mse = \frac{1}{N} \sum_{i=1}^N (y_i - \hat{y}_i)^2 \quad (2)$$

Where  $y_i$  represents the actual value of  $i$ th member of output vector and  $\hat{y}_i$  is the corresponding value estimated value. Two importance measures, accuracy improvement factor (AIF) and accuracy reduction factor (ARF) have been proposed to characterize the importance of a particular sensor in the virtual network owing to input perturbations. AIF for a particular sensor is to reflect a sensor's importance on network estimations when the signal from that particular sensor is correct and remaining sensors are uncertain. AIF can be computed from equation (3)

$$AIF^{(i)} = \frac{mse^{(i)} - mse^{(n)}}{mse^{(n)}} \quad (3)$$

Where  $mse^{(i)}$  and  $mse^{(n)}$  are the values of 'mse' when only the signal from  $i$ th sensor is correct and when signals from all other 'n-1' sensors are uncertain. A lower value (close to zero) of  $AIF^{(i)}$  would indicate the higher importance to network estimations and a relatively lesser influence of uncertainties in the remaining members of the network. This means that the particular virtual sensor network would produce accurate results provided the signal at the sensor having smallest AIF is secured.

Another metric to assess the importance of a sensor is ARF which is to represent a sensor importance when it is uncertain and the remaining sensors are correct. ARF can be computed from equation (4)

$$ARF^{(i)} = \frac{mse^{(n)}}{mse^{(i,n-1)}} \quad (4)$$

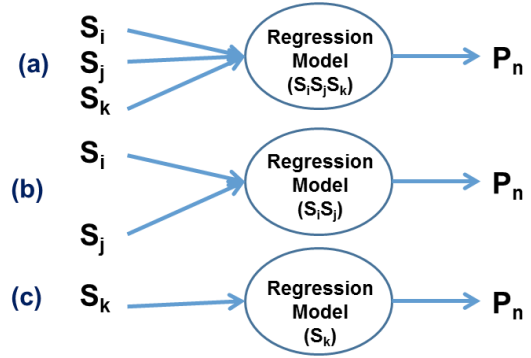

Figure 4: Input combinations for generating similar output parameter from neural networks.

Where  $mse^{(i,n-1)}$  and  $mse^{(n)}$  are the values of 'mse' when only the signal from  $i$ th sensor is corrupted and all other signals from 'n-1' sensors are correct. The value of ARF for a particular sensor will always lie between zero and one. A value close to zero would indicate higher sensitivity of model estimation to the perturbations in a particular sensor, and a value close to unity would indicate otherwise. This means that the estimations from a particular virtual sensor network are quite sensitive to the perturbations in the signal of sensor having smallest ARF value.

It should be noted that AIF and ARF are based on estimations computed from a regression model and would adhere to the characteristics of that regression model. Therefore, AIF and ARF reflect a sensor's characteristics in a virtual sensor network, which is a group of sensors whose inputs are integrated using a regression model.

## 4. ANALYSIS AND RESULTS

This section describes the application of the presented methodology for developing system-specific relations for containment spray system during a specific LOCA scenario. The LOCA scenario was assumed to follow the sequence of events shown in table 1. We can recognize three important phases of this accident in time, 1) starting from pipe break in the primary system followed by success/failure of several systems till the start of containment sprays at 1,280 sec, 2) time interval during which containment spray system worked and eventually expired at 7,730.2 seconds and recirculation system came into play, and 3) time interval starting with the recirculation system's action to the failure of containment.

The first part within the first 1,280 seconds following the accident was marked by action and failure of several safety features which was quite rapid and therefore, an effort to apply proposed methodology would be quite uncertain and have limited applicability due to many influencing parameters in practical situation.

Table1: Sequence of events following LOCA simulated in MAAP for OPR-1000.

Action	Time (seconds)
PZR heaters on	1.2
PZR heaters off	10.4
HPI on	11.7
Reactor scram	11.7
Motor-driven Auxiliary feed-water on	11.7
MSIV closed	11.7
Main FW off	11.7
Upper compartment spray on	1280.1
Upper compartment sprays off	7730.2
Recirculation system in operation	7730.2
Accumulator water depleted	247447.2
Containment failed	247447.2

The second part (1,280 – 7,730 seconds) where only the containment spray systems was operational, the proposed methodology was implemented and correlations were computed for PAM parameter with the SAMG parameters. For this part, the explanation for reactor vessel level (RVL) is given. For other parameters the strategy can be directly extended. The parameter RVL was found to have correlation with containment (CNMT) water level measuring sensors, radioactive waste storage tank (RWT) level, containment gas temp, pressurizer (PZR) temperature, cold leg temperature, reactor vessel gas temperature, and temperature measuring devices installed in reactor core, at a correlation coefficient higher than 0.85.

The third part (after 7,730 second), was marked by the build-up of pressure in the containment building which was not controlled by recirculation system and eventually led to the containment rupture.

**4.1. Estimations of PAM**

Since, many virtual sensor networks can be developed depending upon the number of correlated parameters. One representative example for RVL signal recovery in case of original sensor failure is presented here, where candidates for the input were three sensors CNMT water level (m), RWT level (m) and cold leg temperature (K). The variation of input and output parameters is shown in figure 5. The trained neural network was tested against an arbitrary sample taken from the data. The estimation of virtual network against the actual normalized value of RVL is shown in figure 6. The accuracy and sensitivity issues were explored by computing the network importance measures.

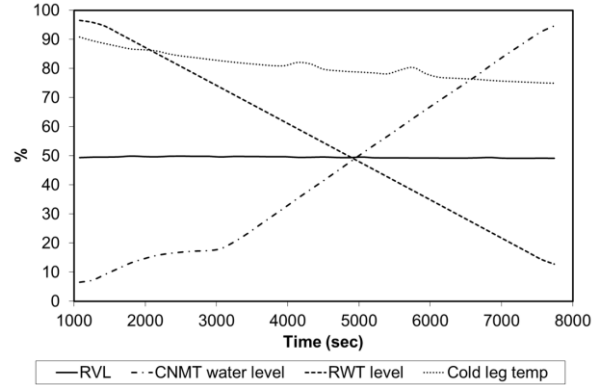

Figure 5: Variation of few correlated parameters with reactor vessel level.

**4.2. Comparison of Importance Measures**

In our network importance measure calculations, AIF for each sensor was computed by assuming a uniform random noise of  $\pm 5\%$  in other members of the network, while during the calculation of ARF the error was considered to be present only in that sensor whose ARF was required. AIF and ARF computed values for the network members are given in table 2. From AIF values the signals CNMT water level, RWT level and cold leg temperature are important to the correct estimations in descending order.

On the basis of ARF values, the network estimations are less sensitive to perturbations ( $< \pm 5\%$ ) to the CNMT water level and more sensitive to the perturbations in RWT level and cold leg temperature.

**4.3. Unavailability Problem**

A common problem of concern is the unavailability of all of instrumentation or a part of it. Of course, the problem of absolute loss of information cannot be resolved by methods relying upon information, therefore the problem of partial loss of information was considered.

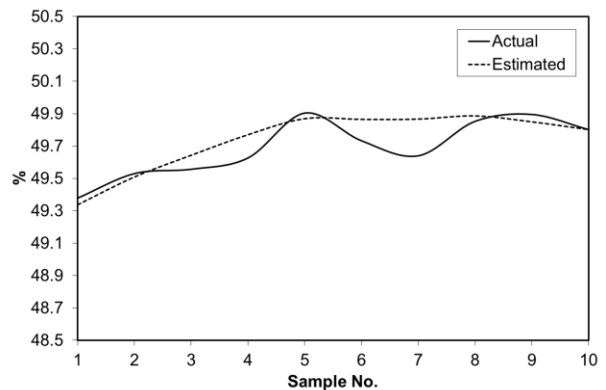

Figure 6: Estimation of RVL using neural network.

Table 2: Network importance measures.

Parameter	AIF	ARF
CNMT water level	41.0685	0.0238
RWT level	71.1913	0.0139
Cold leg temperature	238.0302	0.0043

As mentioned in section 3.4, several virtual networks of varying size and combinations of inputs can be used to estimate the same parameter. A new measure, correlation voting index (CVI) helps to identify faulty sensor and to identify the outputs to be relied upon (Ahmed, 2013). The mathematical form of CVI is given by

$$CVI(i) = \sum_{j=1}^n corr(P(i, j)) \quad (5)$$

In equation (5)  $CVI(i)$  is correlation voting index for  $i$ th neural network,  $P$  is matrix of estimated outputs from 'n' neural networks and ' $corr(P(i, j))$ ' is used here to represent function to calculate correlation coefficient between the  $i$ th and  $j$ th estimation of 'n' neural networks stored in matrix  $P$ . The small values (especially negative) of CVI indicate the outliers due to their poor correlation with the rest of the estimations. The highest values of CVI represent the set of outputs from networks with lesser uncertainty.

For the RVL estimation, a set of neural networks like shown in figure 4 were developed. Three cases, representing failures of one signal, 1)  $S_1$ : CNMT water level, 2)  $S_2$ : RWT level and 3)  $S_3$ : cold leg temperature, respectively were analyzed. The CVI values for each network for each case are given in table 3. The positive values represent the consistent set of outputs. For instance for case-I ( $S_1$  unavailable), the acceptable outputs set are produced by networks  $S_2$ ,  $S_3$ ,  $S_1S_3$ , and  $S_2S_3$ . A unity value 1 for  $S_1$  corresponds to the faulty sensor. The final estimation can be computed either by relying only upon the highest value of CVI, in this case for  $S_2S_3$  network (Ahmed, 2013) or by using the mixing models techniques discussed by (Bishop, 2006).

Table 3: CVI computed values for six neural network outputs.

Neural network	CVI (case I)	CVI (case II)	CVI (case III)
$S_1$	1.0000	0.7950	0.5826
$S_2$	1.4255	1.0000	1.2569
$S_3$	1.5624	0.8183	1.000
$S_1S_2$	-1.2737	-0.6058	1.2781
$S_1S_3$	1.0229	0.9360	-0.3763
$S_2S_3$	2.0604	-0.6208	-0.3605

## 5. CONCLUSIONS

In this research, the statistical relationship among the process parameters has been analyzed. The proposed methodology has been demonstrated for a specific LOCA scenario for the time interval where containment spray system was initiated at a particular instant of accident propagation. Virtual sensor network constructed for the estimation of RVL demonstrates the realization of methodology and its improvement is expected by utilizing other networks and importance measures. The CVI performs to select a set of related outputs and gives a yardstick for comparing results in case exact values are not known. However, to extend this strategy for real power plant application requires the evaluation of system-specific relationships via neural networks at safety system's operation set-points and for a set of conditions expected to occur at a power plant. There is a need to bring improvements and refinements to the proposed methodology in the areas of parameter grouping and generalization and optimization of neural networks. Also, the neural networks can also be replaced by other regression technique. The importance measures presented in this study can be defined on the basis of any other performance measures for a regression technique however, it should be remembered that these measures represent importance determined by the characteristics of underlying regression technique and not the importance in physical sense.

The application of the proposed methodology has been demonstrated in the aspect of virtual redundancy of a sensor's information, and unavailability problem. The first would lead to the capability of online validation of critical sensors without installing more physical sensors and the second would provide the capability of estimating critical parameters in case of partial loss of instrumentation along-with the identification of faulty sensors.

## ACKNOWLEDGEMENT

This work was supported by I-NERI funded by Ministry of Education, Science and Technology (Grant Number: NRF-2012M2A8A2056760).

## NOMENCLATURE

<i>AIF</i>	accuracy improvement factor
<i>ANN</i>	artificial neural network
<i>ARF</i>	accuracy reduction factor
<i>CNMT</i>	containment
<i>Corr</i>	function to compute correlation coefficient
<i>CSS</i>	containment spray system
<i>CVI</i>	correlation voting index
<i>FW</i>	feed water
<i>HPI</i>	high pressure injection
<i>HPSIS</i>	high pressure safety injection system
<i>LPSIS</i>	low pressure safety injection system
<i>mse</i>	mean square error

<i>MSIV</i>	main steam isolation valve
<i>PAM</i>	post-accident monitoring
<i>PZR</i>	pressurizer
<i>RVL</i>	reactor vessel level
<i>RWT</i>	radioactive waste storage tank
<i>SA</i>	severe accident
<i>SAM</i>	severe accident management
<i>SAMG</i>	severe accident management guidelines

## REFERENCES

- Ahmed, R., (2013). Study on Process Parameters to Optimize the Monitoring System for Severe Accidents, PhD Thesis. Yongin-si, Giheung-gu: Kyung Hee University.
- Ahmed, R., Heo, G. & An, S. H., (2012). Intelligent Condition-based Maintenance using Plant Health Index. San Diego CA, s.n.
- Ahmed, R. et al., (2013). Study on Virtual Redundancy among Process Parameters for Accident Management Applications. Gwangju, s.n.
- American Nuclear Society, (2012). Fukushima Daiichi: ANS Committee Report, s.l.: ANS.
- Beale, M. H., Hagan, M. T. & Demuth, H. B., (2012). Neural Network toolbox User's Guide 2012a. s.l.:The MathWorks Inc. .
- Bishop, C. M., (2006). Pattern Recognition and Machine Learning. LLC, USA: Springer Science + Business Media.
- Fausett, V. L., (1994). Fundamentals of Neural Networks: Architectures, Algorithms And Applications. s.l.:Prentice Hall International.
- IAEA, (2002). Accident Analysis of Nuclear Power Plants, Safety Reports Series No. 23, Vienna: International Atomic Energy Agency.
- IEEE Power and Energy Society, (2010). IEEE Standard Criteria for Accident Monitoring Instrumentation for Nuclear Power Generating Stations: IEEE Std 497 2010 (Revision of IEEE Std 497-2002. New York: IEEE.
- Masters, T., (1993). Practical Neural Network Recipes in C++. San Diego, California: Academic Press, Inc..
- Park, K. A. a. S., (2009). Development of a Risk-informed Accident Diagnosis System to Support Severe Accident Management. Nuclear Engineering and Design, Volume 239, pp. 2119-2133.
- US Nuclear Regulatory Commission, (1983). Regulatory Guide 1.97: Revision 3, Instrumentation for Light-water Cooled Nuclear Power Plants to Assess Plant and Environs Conditions During and Following an Accident, s.l.: USNRC.
- Westinghouse Electric Company, (2012). Nuclear Automation: Advanced Logic System Post-accident Monitoring System. [Online] Available at: [www.westinghousenuclear.com](http://www.westinghousenuclear.com) [Accessed May 2013].

## BIOGRAPHY

**Ahmed, Rizwan** was born at Sialkot, Pakistan on January 28th 1983. He graduated from M.Sc. (Geophysics) program in 2004 from Quaid-i-Azam University, Islamabad, Pakistan. He got fellowship in MS Nuclear Engineering at Pakistan Institute of Engineering and Applied Sciences (PIEAS), Islamabad, Pakistan in 2004 and graduated from the program in 2006. He joined Mainformatics Laboratory, Department of Nuclear Engineering at Kyung Hee University (KHU), South Korea in September 2009 and completed his Ph.D. in August 2013. Now, he works as a faculty member at Department of Nuclear Engineering, PIEAS in Pakistan. He has published several journal and conference papers on areas related to nuclear safety problems. His research interests include accident simulation, numerical computing, and PSA. He was awarded with best presentation and paper award by Japanese Society of Mechanical Engineers (JSME) for his publication in ICEM-2010, Japan. He is a member of Korean Nuclear Society (KNS) Korea.